

EM6400NG multi-function meters

Functions and characteristics



EM6400NG series multi-function power meter

Functions and characteristics

Introducing EM6400NG, next generation power meters of iconic EM6400 series with innovative features to meet the needs of energy efficient India.

Accurate measurements of THD and individual harmonics (complying with IEC61557-12) helps in monitoring the power quality. It enables the users to capture abnormalities in the system with date and time stamp. Further to facilitate the readings, the EM6400NG has a large LED display for simultaneous monitoring of multiple electrical parameters. Cyber security features to enable safe and secure Digital India.

Available meter models in EM6400NG series are:

- EM6400NG POP (Class 1.0 and 0.5S)
- EM6400NG RS485 (Class 1.0, 0.5S, and 0.2)

Applications

Cost management:

- Electrical installation remote monitoring.
- Energy accounting and balancing.
- Tenant and sub-billing.
- Panel instrumentation.
- Energy management.

Network management:

- Power quality analysis: THD and individual harmonics up to 15th order for Volts and Amps, per-phase.
- Measurement of both True PF and Displacement PF.
- Recording Min/ Max values of instantaneous parameters with date and time stamp.

Main characteristics:

- Easy to install: Mounts using two clips and no tools are required. Compact meter with maximum of 73 mm depth, connectable up to 480 +/- 10% AC Volts L-L without voltage transformers for installations compliant with measurement category III, and double insulated.
- Easy to operate: Test LED at the front panel can be used for test and calibration of the meter at site or laboratory. Heart beat LED indicates the normal functioning of the meter and communication status if connected to RS485 network.
- LED display: Intuitive navigation with self-guided, three buttons, LEDs of height ~14.2 mm (0.55 in), and three lines of concurrent values. Two columns of LEDs given on the either side of the meter's front panel indicates the parameter name chosen for display.
- Energy standards: Active energy Class 0.5S/ Class 0.2+1 as per IEC 62053-22, Active energy Class 1.0 as per IEC 62053-21. Reactive energy Class 1.0 & Class 2.0 as IEC 62053-24 & IEC 62053-23 respectively. Tested in accordance with IEC 62052-11 standard for -
 - 5 A, I-nominal
 - 1 A, I-nominal (field settable).

- Power quality analysis: The EM6400NG offers THD measurements and Individual harmonics up to 15th order for voltage and current parameters, per-phase basis.

- Load management: Peak demands of all the four demand parameters (W, VA, VAR, Amps) with date and time of occurrence.

- Billing: Tenant billing/utility meter cross check (where local regulations are not applicable).

- Load timer: Load timer (Run Hrs) monitors and advises maintenance requirements.

- Password: Field configurable password for securing set up information and prevents tampering of integrated values.

- Cyber security: Option for disabling RS485 port through front panel keys against unauthorized access. This feature can also be used for toggling between the RTU devices in case of limited availability of nodes in software system.

- Display: Auto scaling, 9+3 digits for energy, and 4 digits for other parameters.

Model reference	Commercial reference
EM6400NG POP CI 1.0	METSEEM6400NGPOCL1
EM6400NG POP CI 0.5S	METSEEM6400NGPOCL5
EM6400NG RS485 CI 1.0	METSEEM6400NGRSL1
EM6400NG RS485 CI 0.5S	METSEEM6400NGRSL5
EM6400NG RS485 CI 0.2	METSEEM6400NGRSL2

EM6400NG multi-function meters

Functions and characteristics

PB115132



EM6400NG series multi-function power meter - front

General

Use on LV and MV systems with PT/CT ratio programmable at site

Basic metering with THD, Individual Harmonics, RTC, and min/max readings

Instantaneous RMS values

Current	Average line current of 3-phase, per-phase, and calculated neutral current
Voltage	Average voltage of L-L, L-N parameters, and per-phase
Frequency	Any available line
Real, reactive, and apparent power	Total and per-phase value
Displacement power factor	Average and per-phase signed, four quadrant
True power factor	Average and per-phase signed, four quadrant

% unbalance among the phase for I, V L-N, V L-L

Energy values stored in non-volatile memory

Accumulated Active, Reactive and Apparent Energy, Received and Delivered registers

Net and absolute energy values, time counters

Old Registers facilitate retrieval of last cleared Energy values through communication

Demand values

Current average	Present, Last, Predicted, Peak, and Peak Date Time
Active power	Present, Last, Predicted, Peak, and Peak Date Time
Reactive power	Present, Last, Predicted, Peak, and Peak Date Time
Apparent power	Present, Last, Predicted, Peak, and Peak Date Time
Demand sync methods	Thermal, Timed, Command Sync, and Clocked Sync
Demand calculation mode	Sliding, fixed and rolling block

Demand intervals are settable from 1 to 60 minutes, in the step of 1 minute

Display

Bright red colour LED display, 7 segment LED, ~ 14.2 mm (0.55 in) height, 3 rows with 4 digits per row, Auto range

Communication

Pulse Output: Rate of pulse can be configured for selected energy parameters

RS485 serial channel connection Industry standard Modbus RTU protocol

Integration with any Modbus compatible SCADA/ DCS/ PMS/ EMS/ BAS/ BMS software

Native Plug and Play support for Schneider Electric energy management system software - StruxureWare Power Monitoring Expert, StruxureWare PowerSCADA Expert along with ION Setup programming support

Min/Max values

Meter records Minimum & Maximum values for 8 parameters, viz., V L-L, V L-N, Amps, PF, Hz, W, VA, VAR with date and time stamp. Values can be reset separately in set up mode

Diagnostics

Diagnostic page indicates the healthiness of communication system, all LED test, device serial number and OS & RS version

Page Lock

Page Lock & Un-Lock features: Once commonly referred page is enabled for Lock feature, the display returns to Locked page in 4 minutes of inactive time

EM6400NG multi-function meters

Functions and characteristics



EM6400NG series multi-function power meter - rear

Electrical characteristics	
Type of measurement	True RMS, 64 samples per cycle
Measurement accuracy	
Current, Phase	±0.5%
Voltage L-N, L-L	±0.5%
Power Factor	±0.01
Power	±0.5%
Frequency	±0.05%
Real Energy	Class 0.5S and Class 0.2 ⁺¹ as per IEC 62053-22 and Class 1.0 as per IEC 62053-21 for both CT nominal of 5 A and 1 A ⁺²
Reactive Energy	IEC 62053-23 Class 2.0 when Wh Class is 1.0 and IEC 62053-24 Class 1.0 when Wh Class is 0.5S/0.2
THD and Individual Harmonic, V & A	Class 5.0 as per IEC 61557-12 for THD and individual harmonics up to 15th
Input-voltage	
VT primary	999 kV L-L max, starting voltage depends on VT ratio
U nominal	277 V L-N/480V L-L
Measured V with full range	35 to 600 V AC L-L
Permanent overload	750 V AC L-L
Impedance	=> 5 MΩ
Frequency range	50/60 Hz +/-5%
VA burden	< 0.2 VA at 240 V AC L-N
Input-current	
CT ratings	Primary adjustable 1 A to 32768 A Secondary 1 A or 5 A I-nominal
Measured Amps with over range & Crest Factor	5 mA to 6 A
Withstand	Continuous 12 A, 50 A at 10 sec/hr
Impedance	< 0.3 MΩ
Frequency range	50/60 Hz +/-5%
VA Burden	< 0.1 VA at 6A
AC control power	
Operating range	44- 277 V AC ± 10%
Burden	< 6 VA at 277 V L-N
Frequency	50/60 Hz nominal
Ride-through time	100 ms typical at 120 V AC and maximum burden 100 ms typical at 277 V AC and maximum burden
DC control power	
Operating range	44-277 V DC ± 10%
Burden	< 2 W at 277 V DC
Ride-through time	50 ms typical at 125 V DC and maximum burden
Real time clock	
Ride-through time	3 years
Displays update	
Instantaneous	1 s
Demand	15 s
Harmonics	5 s
Wiring configuration	
User programmable	1ph, 2w, LN 1ph, 2w, LL 1ph, 3w, LL with N (2phase) 3ph, 3w, Delta, Ungrounded 3ph, 3w, Delta, Corner Grounded ⁺³ 3ph, 3w, Wye, Ungrounded ⁺³ 3ph, 3w, Wye Grounded ⁺³ 3ph, 3w, Wye, Resistance Grounded ⁺³ 3ph, 4w, Open Delta, Center-Tapped ⁺³ 3ph, 4w, Delta, Center-Tapped ⁺³ 3ph, 4w, Wye, Ungrounded ⁺³ 3ph, 4w, Wye Grounded 3ph, 4w, Wye, Resistance Grounded ⁺³

⁺¹ Class 0.2S accuracy is applicable in 3ph,4w configuration

⁺² For 1 A CT nominal, additional error of ±1% from 50 mA to 150 mA, ±2% for current > 10 mA to < 50 mA

⁺³ Through communication

EM6400NG multi-function meters

Functions and characteristics

PB115134

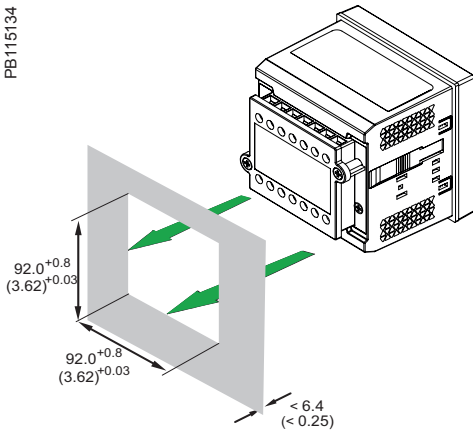

EM6400NG multi-function meter flush mounting type

Mechanical characteristics	
Weight	~ 600 gms (21 oz)
IP degree of protection	IP51 front side, IP30 meter body as per IEC 60529
Material	Polycarbonate meets UL 94V-0 flammability rating
Dimensions W x H x D	96 x 96 x 73 mm (3.78 x 3.78 x 2.87 in) maximum (depth of the meter from housing mounting flange) and 13 mm (0.51 in) (protrusion of meter from housing flange)
Mounting position	Vertical
Panel thickness	5 mm (0.196 in) maximum
Environmental characteristics	
Operating temperature	Meter -10 to +60 °C (+14 to +140 °F)
Storage temperature	Meter -20 to +70 °C (-4 to +158 °F)
Humidity rating	5 to 95% RH at 50 °C (122 °F) (non-condensing)
Pollution degree	2
Altitude	2000 m (6561 ft) Category III
Product life	> 7 years
Electromagnetic compatibility (as per IEC 62052-11)	
Electrostatic discharge	IEC 61000-4-2
Immunity to radiated field	IEC 61000-4-3
Immunity to fast transients	IEC 61000-4-4
Immunity to impulse waves	IEC 61000-4-5
Conducted immunity	IEC 61000-4-6
Immunity to magnetic field ⁴	IEC 61000-4-8
Immunity to voltage dips	IEC 61000-4-11
Emission ⁴	Emissions FCC Part 15 Class A/CE
Safety	
Europe	CE, as per IEC 61010-1 Ed-3
US and Canada	cULus as per UL61010-1 and CAN/CSA-C22.2 No. 61010-1, for 600V AC
Measurement category (Voltage and Current inputs)	CAT III up to 480 V L-L CAT II up to 600 V L-L
Overvoltage category (Control power)	CAT III up to 300 V L-N
Dielectric	As per IEC/UL 61010-1 Ed-3
Protective Class	II, Double insulated for user accessible parts
Other certification	C-Tick (RCM)
Communication	
RS485 port	Modbus RTU: 2-Wires, 4800, 9600, 19200 or 38400 baud, Parity - Even, Odd, None, 1 stop bit if parity is Odd or Even, 2 stop bits if None DLF3000: Firmware update through communication port
Pulse Output (POP)	Max 40 V DC, 20 mA 20 ms ON time Configurable pulse weight from 1 to 9999000 pulses/k_h (kWh, kVAh, or kVARh)
Isolation	2.5 kV RMS, double insulated
Protection features	Password protected for set-up & clearing energy and Min/Max data
Display language	English
Technical publication	Printed installation guide (QSG) with meter and user guide in soft format
Human machine interface	
Display type	7 segment LED, ~ 14.2 mm (0.55 in) height, 3 rows with 4 digits per row 2 columns of LEDs at either side of the LED panel to indicate the parameters under measurement 9+3 digit format for energy and 4 digit for other parameters
Keypad	3 buttons for navigation & combination of 2 buttons for performing Set up, Lock/ Unlocking of pages, Diagnostic page operation
CAL LED Indicator	Red colour, meter constant is configurable from 1 to 9999000 pulses/k_h (kWh, kVAh, or kVARh)
Comm. activity	Green LED (for indicating RS485 interface or heartbeat pulse)

⁴ Tested as per IEC 61326-1 standard

EM6400NG multi-function meters

Functions and characteristics

Feature set summary

Parameter	EM6400NG POP	EM6400NG RS485
Accuracy Class for Wh	1.0 0.5S	1.0 0.5S 0.2
Accuracy Class for VARh	2.0 1.0	2.0 1.0
Sampling rate per cycle	64	64
Amps: per-phase, average and calculated neutral current	■	■
Voltage: V L-N, V L-L - per-phase and average	■	■
Power Factor	True PF	True PF, Displacement PF ⁺³
Frequency (any available phase)	■	■
Power: W, VA, VAR - per-phase and total	■	■
3-ph unbalance	Current	Current, Voltage ⁺³
Demand parameters (W, VA, VAR, Amps) Date and timestamp for peak demand ⁺³	■ (no timestamp)	■
Energy: Wh, VAh, VARh (4 quadrants) Delivered (Import or Forward), Received (Export or Reverse)	Delivered, Received	Delivered, Received Total ⁺³ , Net ⁺³ , Last cleared ⁺³
Power On hours, Load Run hours and Power Outage ⁺³	-	■
THD: Voltage L-N or L-L, Amps per phase	■	■
Individual Harmonics ⁺³	-	up to 15th
Min/Max with Real time clock ⁺³ For V L-L, V L-N, Amps, PF, Hz, W, VA, VAR	-	■
Communication (any one feature)	POP	RS485 Modbus RTU

⁺³ Through communication

EM6400NG multi-function meter dimensions

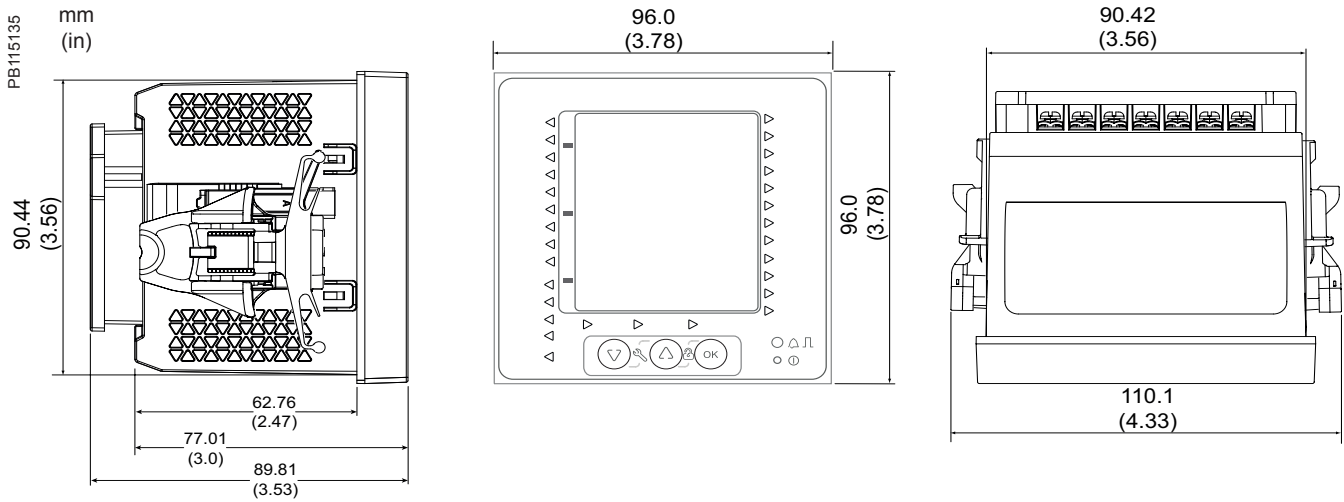

EM6400NG multi-function meter display overview

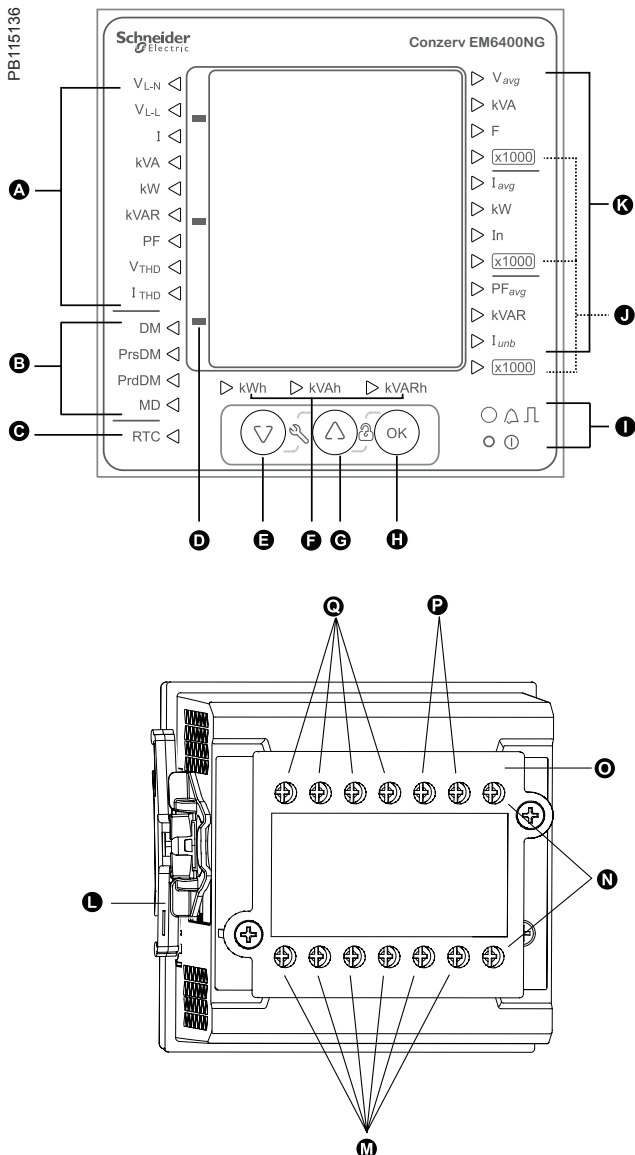

A	Phase measurements	VL-N, VL-L, I, kVA, kW, kVAR, PF, VTHD, ITHD
B	Demand measurements	DM, PrsDM, PrdDM, MD
C	RTC	Date and time
D	Negative indicator	
E	Navigation key	To navigate down
F	Energy readings	Apparent energy, Active energy, and Reactive energy
G	Navigation key	To navigate up
H	OK	Enter key
I	Energy pulsing LED (Red), Heartbeat / communications LED (Green)	
J	x 1000 indicator	
K	System measurements	Vavg, kVA, F, Iavg, kW, In, PFavg, kVAR, Iunb
L	Retainer clip	
M	Input current terminals	A1(S1, S2), A2 (S1, S2), A3 (S1, S2)
N	RS-485 communications/ POP terminals	D1+, D0-
O	Protective cover	
P	Auxiliary power supply (control power) terminals	L+, N-
Q	Input voltage terminals	V1, V2, V3, VN

Contact Details:

Industrial Supply Syndicate
 54, Ezra Street, Kolkata - 700 001, INDIA
 Phone: 22350923, 22356676 Fax: +91 33 32916080
 Email: info@industrialindia.com Website: www.industrialindia.com